

CUVETTE FOR IR SPECTROSCOPY OF HIGHLY ABSORBING FLUIDS  
AT HIGH PRESSURES AND TEMPERATURES

I. V. Babashov, G. V. Bondarenko, Yu. E. Gorbatyi, UDC 543.42:621.3.029.67/672  
and M. B. Épel'baum

The article describes a high-temperature, high-pressure cuvette which permits obtaining infra-red (IR) spectra of highly absorbing fluids in the region from 2500 to 4000  $\text{cm}^{-1}$ . The IR spectra of water obtained at pressures of 250 and 500 atm and temperatures to 500°C are presented.

The cuvettes used for obtaining the IR absorption spectra of water at high temperatures and pressures described in [1, 2] are intended for obtaining the spectra of water at pressures and temperatures not exceeding the critical ( $P_c = 218.4$  atm, and  $T_c = 374.1^\circ\text{C}$ ). Only spectra of mutual solutions of water and its deuterio-analogs are obtained in the case of higher parameters [3].

A cuvette for working in the supercritical region is described below. In connection with the high absorption in this region it is necessary to keep the thickness of the absorbing layer to about 1-2  $\mu$ , whereas the high pressure and temperature in the cuvette lead to an increase of the distance between the windows to a much greater magnitude owing to extension of the casing, compression of the thrust bushings, buckling of the threads, thermal expansion, etc. Therefore, the design of the cuvette should permit sufficiently accurate regulation of the distance between the

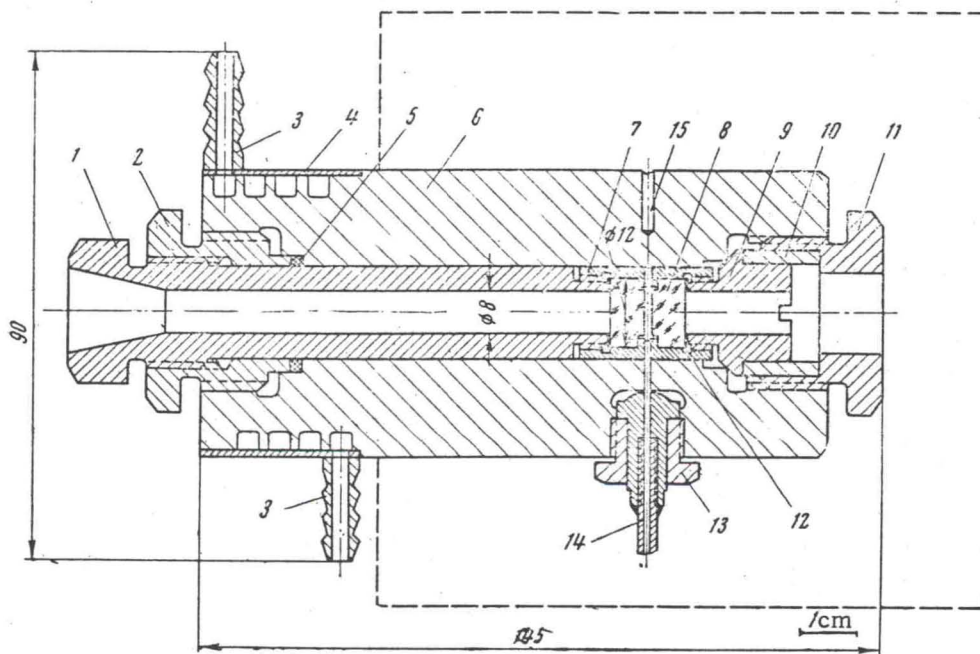

Fig. 1. Cuvette for IR spectroscopy at high pressures and temperature.

Institute of Solid State Physics, Academy of Sciences of the USSR. Translated from *Pribory i Tekhnika Éksperimenta*, No. 2, pp. 215-216, March-April, 1970. Original article submitted June 10, 1969.

© 1970 Consultants Bureau, a division of Plenum Publishing Corporation, 227 West 17th Street, New York, N. Y. 10011. All rights reserved. This article cannot be reproduced for any purpose whatsoever without permission of the publisher. A copy of this article is available from the publisher for \$15.00.

Transmission

Fig. 2

in Fig. cut into 41 mm

The force plate of motor i against trophote sure is capillar

A tem wh ing and To lesse photogr

It from the diaphra that the gion of

1. E
2. W
3. E
4. D
5. F